



PEUGEOT 3008

2009 -

Cat. No. **P/036**

E20 E20 55R-01 4120

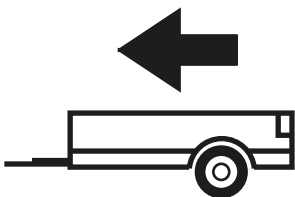

1600kg

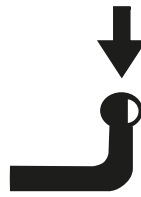

75kg

D = 9,20kN

D (kN) =



MAX kg x MAX kg

x 0,00981



MAX kg + MAX kg

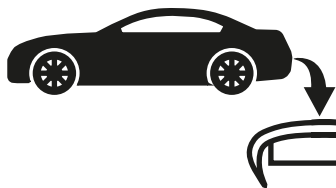

IMIOLA HAK-POL

96-111 KOWIESY, CHOJNATA 23A, POLAND

Tel. + 48 46 831 73 31, fax +48 831 74 29

e-mail: office@imiola.pl, www.imiola.pl



PRZEKRÓJ A-A

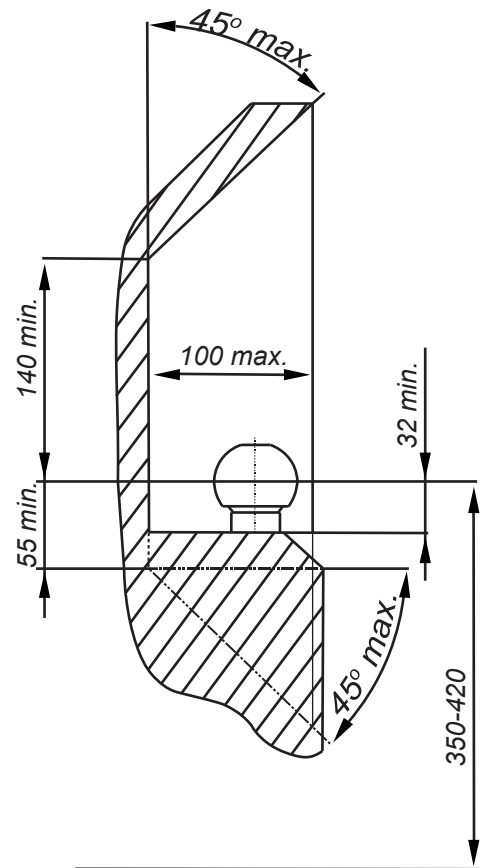

PL Należy zagwarantować przestrzeń swobodną według załącznika VII, rysunek 25a/b Regulaminu EKG ONZ 55.01 przy dopuszczalnym ciężarze całkowitym pojazdu.

F L'espace libre doit être garanti conformément à l'annexe VII, illustration de la réglementation 55.01 CE pour un poids total en charge autorisé du véhicule.

GB The clearance specified in appendix VII, diagram 25a/b of Regulation No. 55.01 UN EU must be guaranteed at laden weight of the vehicle.

D Der Freiraum nach Anhang VII, Abbildung 25a/b der Vorschriften 55.01 EG ist zu gew 25a/bahrleisten bei zulässigem Gesamtgewicht des Fahrzeuges.

Moment skręcający dla śrub i nakrętek (8.8) Torque settings for nuts and bolts (8.8)	
M8	25Nm
M10	55Nm
M12	85Nm
M14	135Nm
M16	195Nm



Nakrętka M10 ; Nut
 Podkl. spręż. 10,2 ; Spring Washer
 Podkl. okr. Ø30x Ø10,5x 3 ; Plain Washer

Nakrętka M12 ; Nut
 Podkl. spręż. 12,2 ; Spring Washer
 Podkl. okr. 13 ; Plain Washer

Nakrętka M10 ; Nut
 Podkl. spręż. 10,2 ; Spring Washer
 Podkl. okr. Ø30x Ø10,5x 3 ; Plain Washer

Śruba M12x40-8.8 ; Bolt

Śruba M12x40-8.8 ; Bolt
 Podkl. spręż. 12,2 ; Spring Washer
 Podkl. okr. 13 ; Plain Washer

Śruba M8x30-8.8 ; Bolt
 Podkl. spręż. 8,2 ; Spring Washer
 Podkl. okr. 8,4 ; Plain Washer

Śruba M12x70-8.8 ; Bolt

Śruba M12x40-8.8 ; Bolt
 Podkl. spręż. 12,2 ; Spring Washer
 Podkl. okr. 13 ; Plain Washer

Śruba M8x35-8.8 ; Bolt
 Podkl. spręż. 8,2 ; Spring Washer
 Podkl. okr. 8,4 ; Plain Washer

Śruba M12x40-8.8 ; Bolt

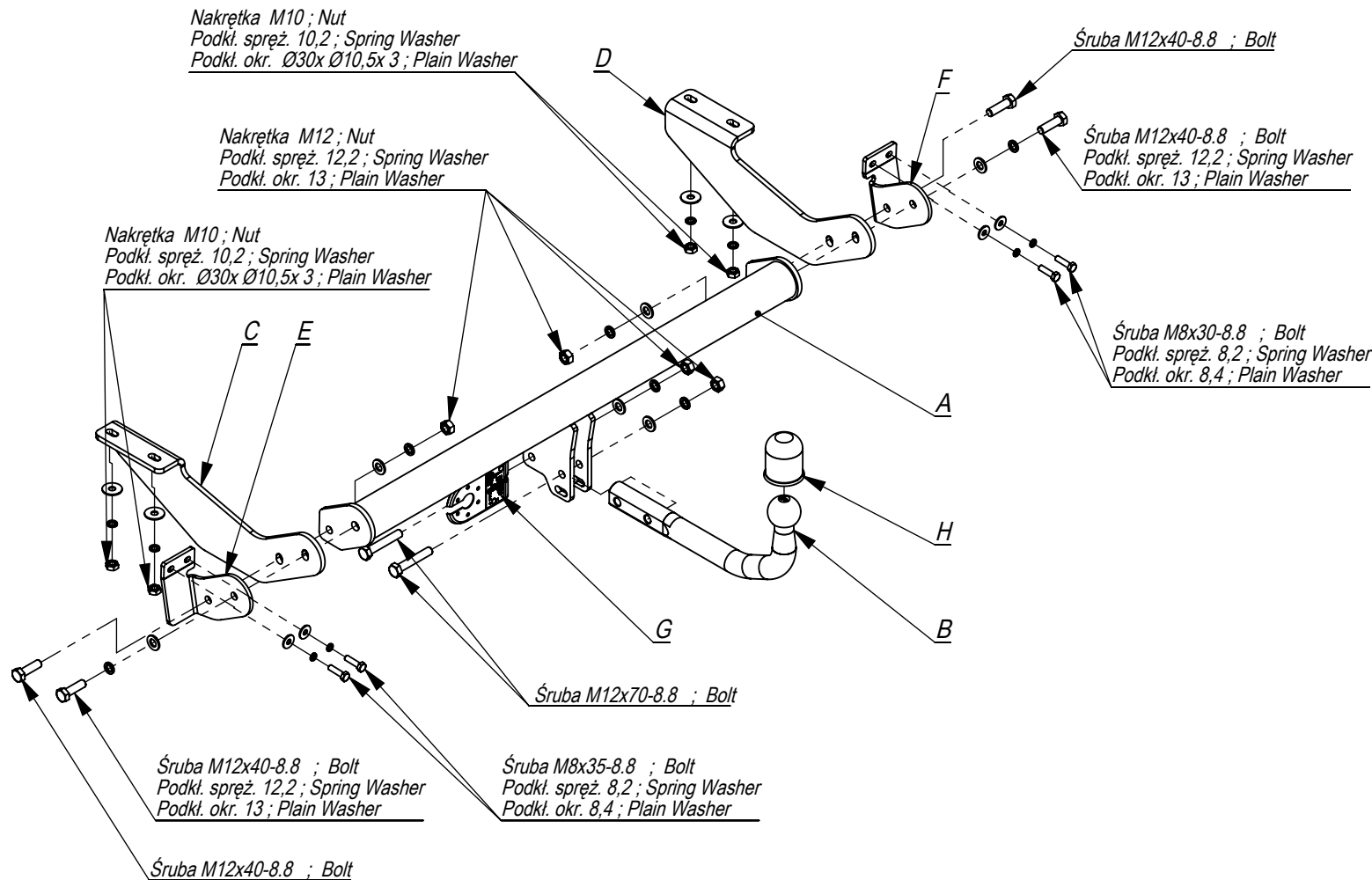

	A	x1		M12x70	2
				M12x40	4
				M8x35	4
	B	x1		M12	4
				M10	4
	C	x1		Ø30xØ10,5x3	4
	D	x1		13	6
				8,5	4
	E	x1		12,2	6
				10,2	4
	F	x1		8,2	4
	G	x1			
	H	x1			

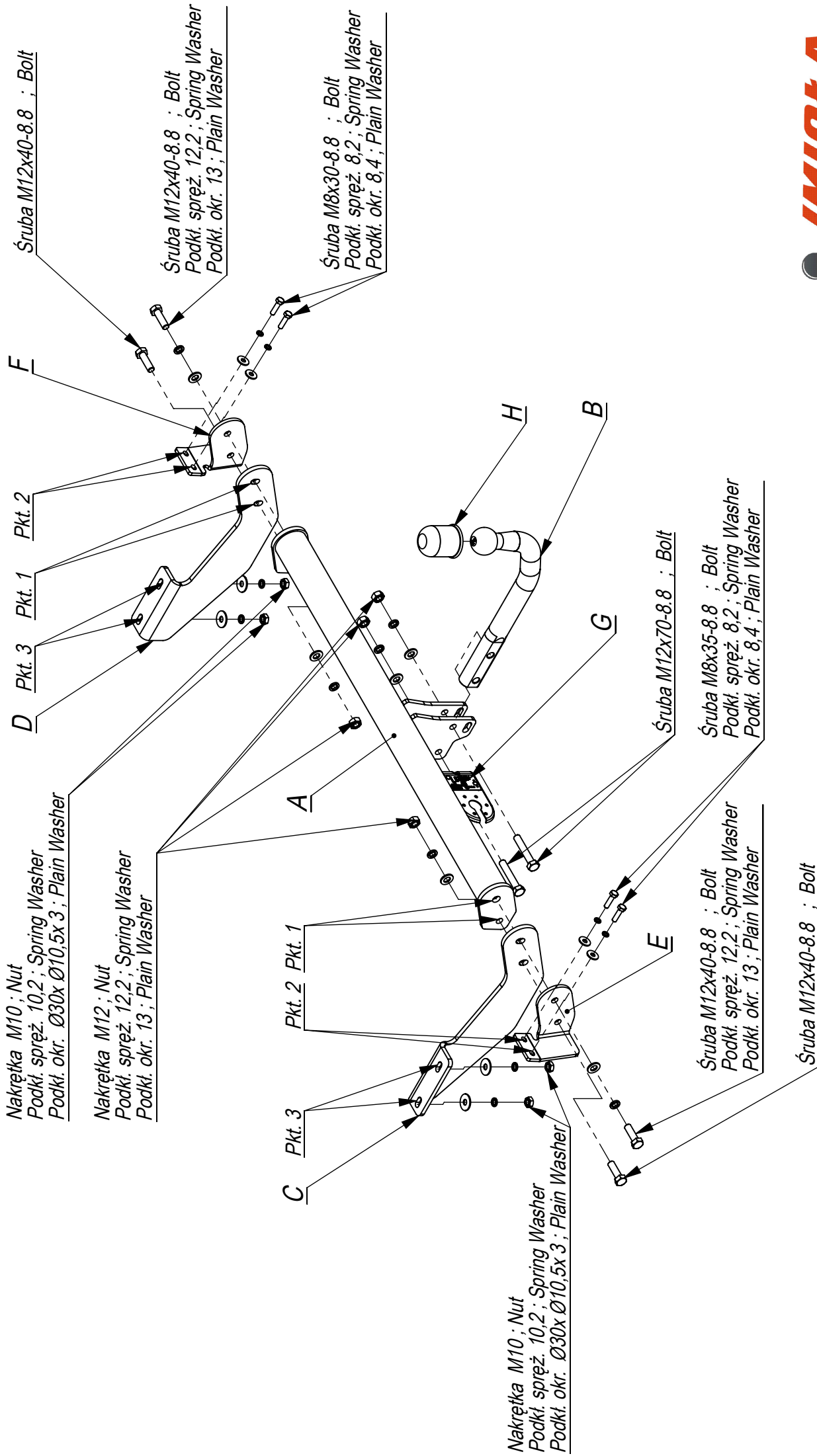

- Zdemontować zderzak.
- Na wystające szpilki w dolnej części podłużnic nałożyć i przykręcić lekko elementy zaczepu C i D nakrętkami M10 (pkt 3).
- Elementy E i F przykręcić do tylnego pasa śrubami M8x35 8.8 (pkt 2).
- Do elementów C i D przykręcić luźno belę haka A śrubami M12x40 8.8 (pkt 1).
- Dokręcić wszystkie śruby z momentem wg tabeli.
- Zamontować zderzak.
- Przykręcić kulę i blachę gniazda elektrycznego śrubami M12x70 8.8.
- Podłączyć instalację elektryczną (zastosuj wiązkę z modułem).

- Disassemble the bumper.
- Put the elements C and D on the protruding pins in the lower part of the metal clamps and screw slightly with nuts M10 (point 3).
- Screw the elements E and F to the rear belt with bolts M8x35 8.8 (point 2).
- Screw slightly the main bar A to the elements C and D with bolts M12x40 8.8 (point 1).
- Tighten all the bolts according to the torque setting- see the table.
- Assemble the bumper.
- Fix the ball and electric plate with bolts M12x70 8.8.
- Connect the electric wires (use the electronic module).

- Déposer le pare-chocs
- Sur les éléments de la broche dans la partie inférieure visser légèrement les éléments du crochet C et D avec les écrous M10 (point 3).
- Visser les éléments E et F à la bande postérieure avec les vis M8x35 8.8 (point 2).
- Aux éléments C et D visser légèrement la poutre du crochet d'attelage A avec les vis M12x40 8.8 (point 1).
- Serrer tous les boulons avec un couple de serrage selon tableau.
- Poser le pare-chocs.
- Visser le crochet d'attelage et socle de prise électrique par les boulons M12x70 8.8.,
- Raccorder le circuit électrique. (utiliser le faisceau avec module).

- Die Stoßstange abschrauben.
- Auf die herausragenden Stiften, im unteren Teil der Längsträger die Tragteile C und D mit den Muttern M10 (Punkt 3) aufsetzen und locker anschrauben.
- Die Tragteile E und F an den hinteren Stoßstange Streifen mit den Schrauben M8x35 8.8 (Punkt 2) anschrauben.
- An die Tragteile C und D den Querbalken A mit den Schrauben M12x40 8.8 (Punkt 1) locker anschrauben.
- Die Stoßstange einbauen.
- Die Kugel und die Steckdosenhalterung mit den Schrauben M12x70 8.8 anschrauben.
- Die Elektroinstallation anschließen. Den Elektrosatz mit Modul anwenden.

- Desenrosque el parachoques.
- Meter los elementos C y D en los tornillos salientes de los largueros (una vez desmontados los soportes), atornillarlos ligeramente por medio de tuercas M12 (punto 3)
- Fijar los elementos C y D a los largueros con tornillos M8x35 8.8 (punto 2).
- Aplique el gancho A a los elementos y apriéte los con pernos M12x40 (punto 1).
- Atornille el parachoques.
- Apriete todos los pernos de acuerdo con la tabla.
- Apriete la bola y la placa del enchufe eléctrico.
- Conecte la instalación eléctrica.

