



KIA VENGA

2009 -

Cat. No. K/027

E20

E20 55R-01

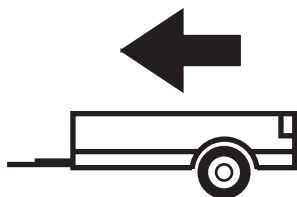

1300Kg



60Kg

D = 7,65kN

D (kN) =



MAX kg

x

MAX kg

x 0,00981



MAX kg

+

MAX kg

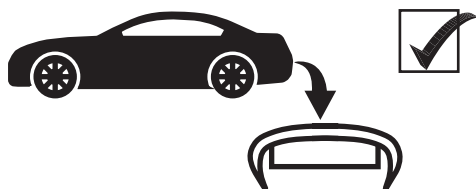

IMIOLA HAK-POL

96-111 KOWIESY, CHOJNATA 23A, POLAND

Tel. + 48 46 831 73 31, fax +48 831 74 29

e-mail: office@imiola.pl, www.imiola.pl

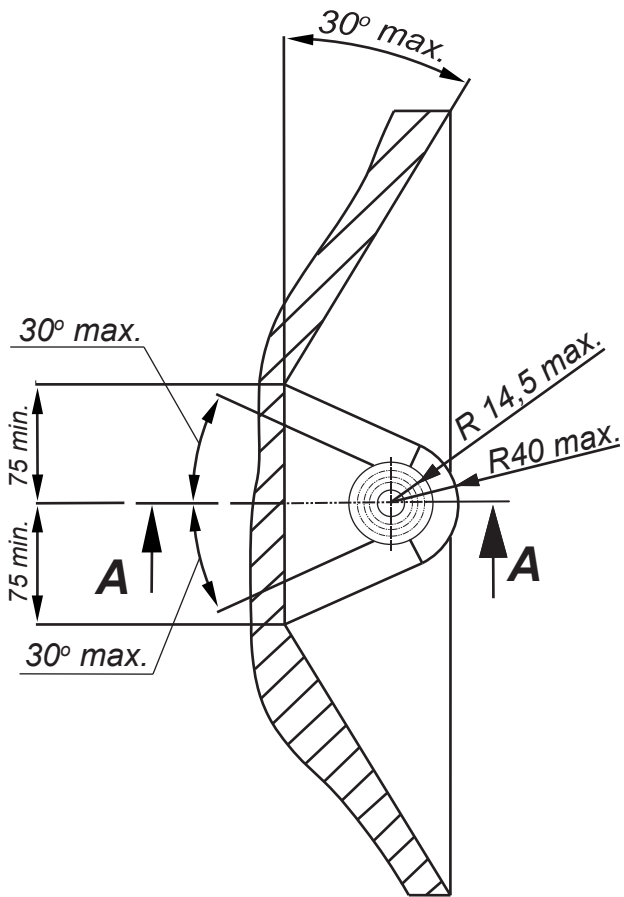

PRZEKRÓJ A-A

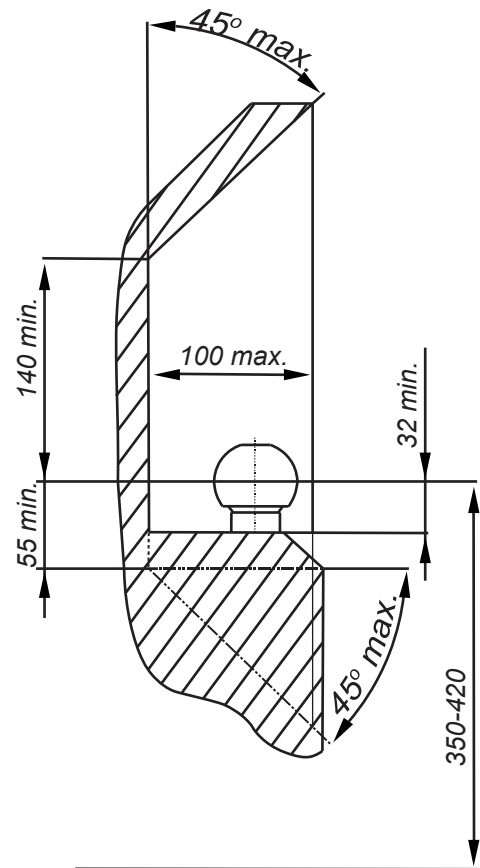

PL Należy zagwarantować przestrzeń swobodną według załącznika VII, rysunek 25a/b Regulaminu EKG ONZ 55.01 przy dopuszczalnym ciężarze całkowitym pojazdu.

F L'espace libre doit être garanti conformément à l'annexe VII, illustration de la réglementation 55.01 CE pour un poids total en charge autorisé du véhicule.





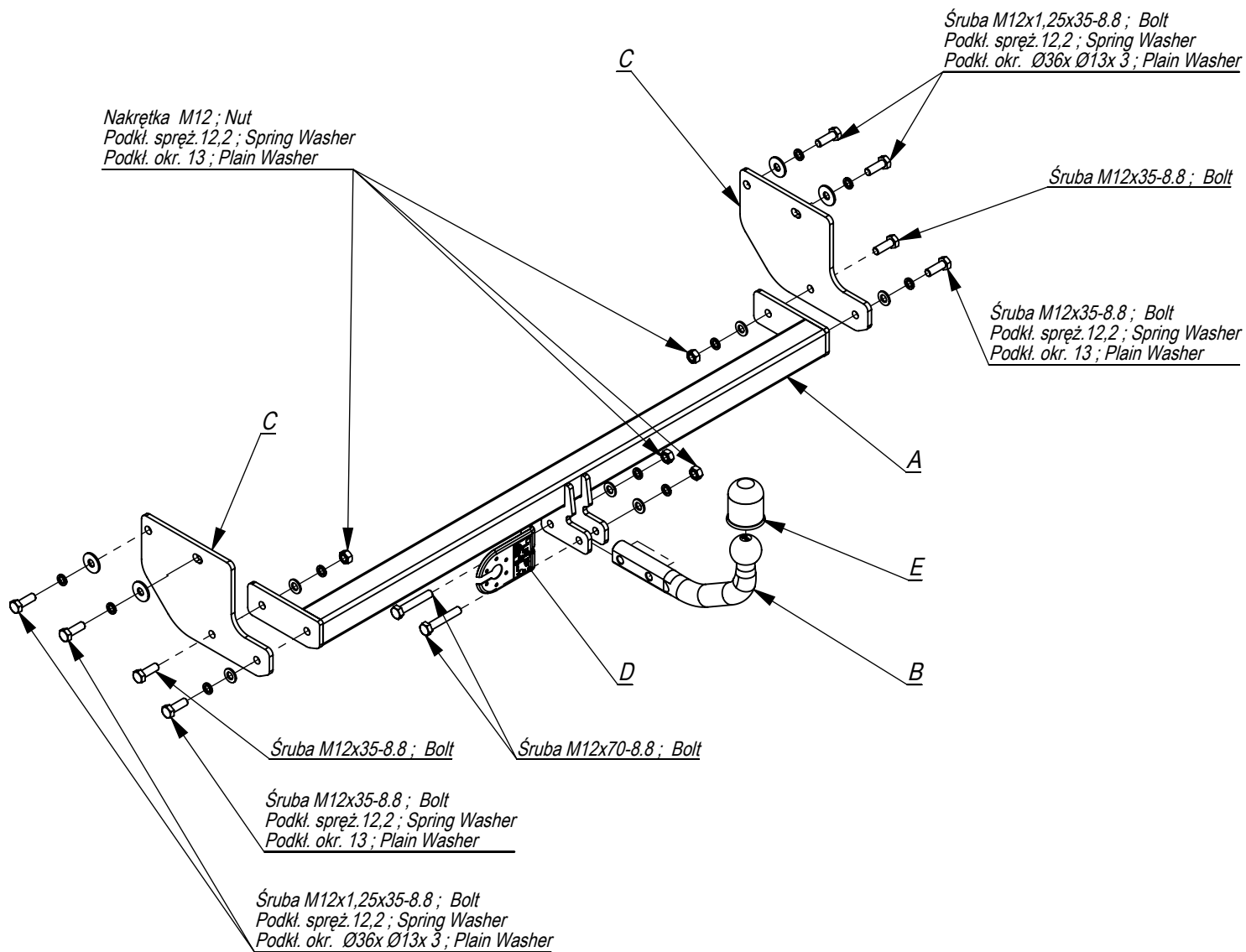

GB The clearance specified in appendix VII, diagram 25a/b of Regulation No. 55.01 UN EU must be guaranteed at laden weight of the vehicle.

D Der Freiraum nach Anhang VII, Abbildung 25a/b der Vorschriften 55.01 EG ist zu gewährleisten bei zulässigem Gesamtgewicht des Fahrzeuges.

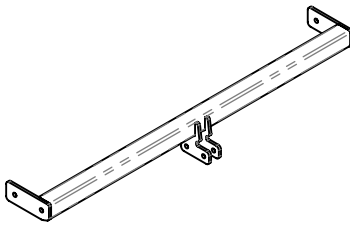
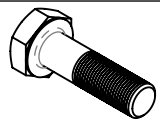
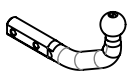
Moment skręcący dla śrub i nakrętek (8.8) Torque settings for nuts and bolts (8.8)	
M8	25Nm
M10	55Nm
M12	85Nm
M14	135Nm
M16	195Nm

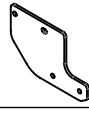
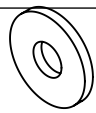



	A	x1		M12x70	2
				M12x35	4
				M12x1,25x35	4
	B	x1		M12	4
	C	x2		Ø36xØ13x3	4
	D	x1		13	6
	E	x1		12,2	10

Śruba M12x1,25x35-8.8 ; Bolt
Podkl. spręż. 12,2 ; Spring Washer
Podkl. okr. Ø36x Ø13x 3 ; Plain Washer

Śruba M12x35-8.8 ; Bolt

Śruba M12x35-8.8 ; Bolt
Podkl. spręż. 12,2 ; Spring Washer
Podkl. okr. 13 ; Plain Washer

Pkt. 1

Pkt. 2

C

A

E

B

D

Śruba M12x70-8.8 ; Bolt

Nakrętka M12 ; Nut
Podkl. spręż. 12,2 ; Spring Washer
Podkl. okr. 13 ; Plain Washer

C

Pkt. 1

Pkt. 2

Śruba M12x35-8.8 ; Bolt

Śruba M12x35-8.8 ; Bolt
Podkl. spręż. 12,2 ; Spring Washer
Podkl. okr. 13 ; Plain Washer

Śruba M12x1,25x35-8.8 ; Bolt
Podkl. spręż. 12,2 ; Spring Washer
Podkl. okr. Ø36x Ø13x 3 ; Plain Washer



96-111 Kowiesy, Chojnata 23 A
tel. +48 46 831 73 31

Marka

KIA Venga

Nr katalogowy

K/027

od 02/10 ->

- Odkręcić zderzak.
- Przykręcić elementy C i D do podłużnic poprzez technologiczne otwory śrubami M12x1,25x35 (pkt 1).
- Do elementów C i D przykręcić belkę haka A śrubami M12x40 8.8 (pkt 2).
- Dokręcić wszystkie śruby z momentem wg tabeli.
- Przykręcić zderzak.
- Podłączyć instalację elektryczną.
- Dokręcić kulę i blachę gniazda elektrycznego.

- Unscrew the bumper.
- Screw the elements C and D to the metal clamps through the technological holes with bolts M12x1,25x35 8.8 (point 1).
- Screw the main bar A to the elements C and D with bolts M12x40 8.8 (point 2).
- Tighten all the bolts according to the torque setting- see the table.
- Screw the bumper.
- Connect the electric wires.
- Fix the ball and electric plate.

- Dévisser le pare-chocs.
- Visser les éléments C et D aux longerons à travers les trous technologiques, avec les boulons M12x1,25x35 (pt 1).
- Visser la barre de crochet A aux éléments C et D avec les boulons M12x40 8.8 (pt 2).
- Serrer tous les boulons avec un couple de serrage selon tableau.
- Visser le pare-chocs.
- Brancher l'installation électrique.
- Serrer la boule et la tôle de la prise électrique.

- Die Stoßstange abschrauben.
- Die Tragteile C und D an die Längsträger durch die vom Werk aus vorhandenen Öffnungen mit den Schrauben M12x1,25x35 (Punkt 1) anschrauben.
- An die Tragteile C und D den Querbalken A mit den Schrauben M12x40 8.8 (Punkt 2) anschrauben.
- Alle Schrauben mit dem in der Tabelle angegebenen Drehmoment festziehen.
- Die Stoßstange anschrauben.
- Die Elektroinstallation anschließen.
- Die Kugel und die Steckdosenhalterung anschrauben.

- Desenrosque las lámparas y el parachoques.
- Fijar los elementos C y D del gancho a los largueros con tornillos M12x35x1,25 8.8 (punto 1).
- Fijar el gancho A a los elementos C y D con tornillos M12x40 8.8 (punto 2).
- Montar el parachoques
- Atornille la bola y la placa de toma de corriente eléctrica. con tornillos M12x70 8.8.
- Apretar todos los tornillos al torque de acuerdo con la tabla.
- Conectar la instalación eléctrica.

