



2008 - 10/2016

# AUDI Q5

Cat. No. **A/A16**

**E20**

E20 55R-01 3523

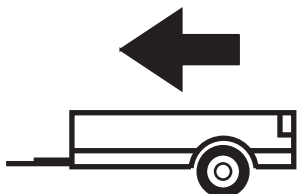

2400kg

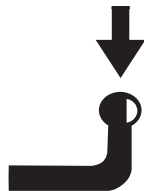

100kg

**D** = 11,88kN

**D (kN) =**



MAX kg

x

MAX kg

x 0,00981



MAX kg

+

MAX kg



IMIOLA HAK-POL

96-111 KOWIESY, CHOJNATA 23A, POLAND

Tel. + 48 46 831 73 31, fax +48 831 74 29

e-mail: [office@imiola.pl](mailto:office@imiola.pl), [www.imiola.pl](http://www.imiola.pl)

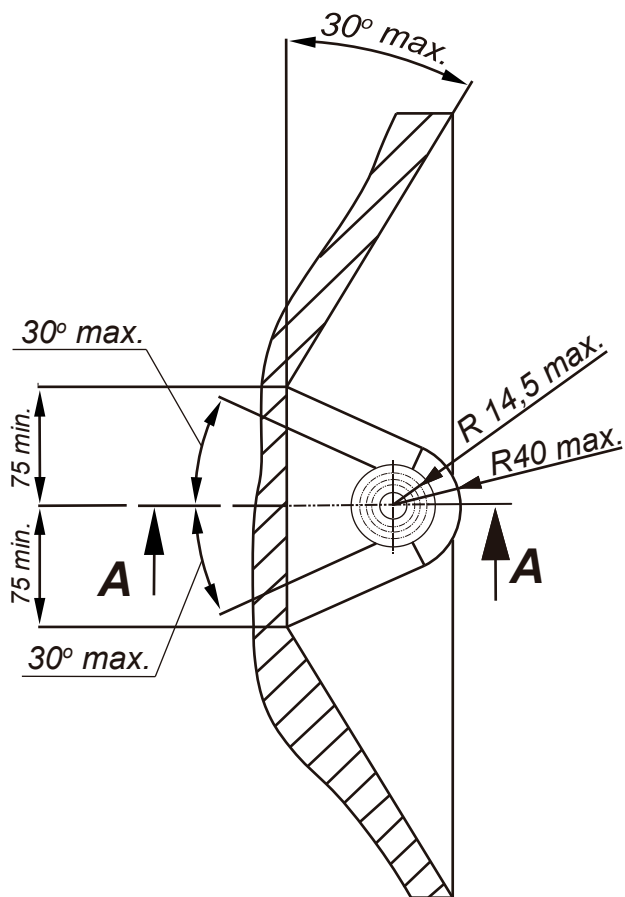

## PRZEKRÓJ A-A

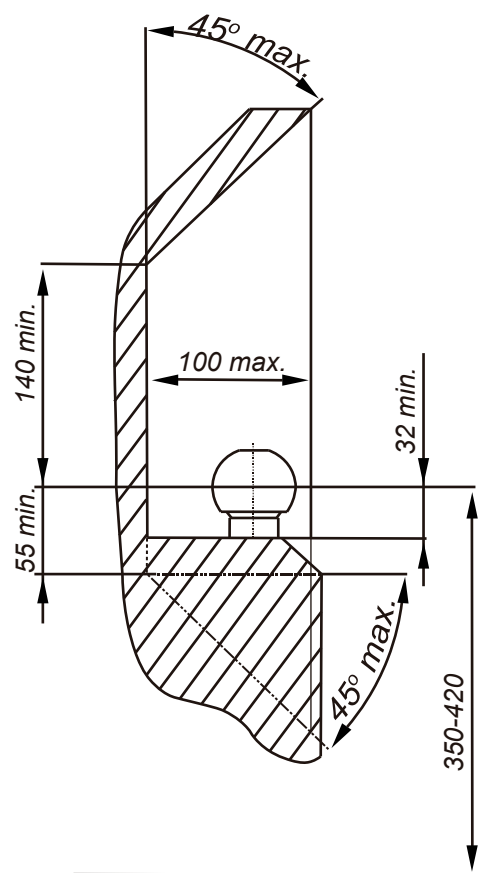

**PL** Należy zagwarantować przestrzeń swobodną według załącznika VII, rysunek 25a/b Regulaminu EKG ONZ 55.01 przy dopuszczalnym ciężarze całkowitym pojazdu.

**F** L'espace libre doit être garanti conformément à l'annexe VII, illustration de la réglementation 55.01 CE pour un poids total en charge autorisé du véhicule.







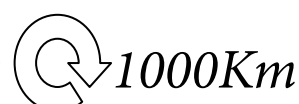

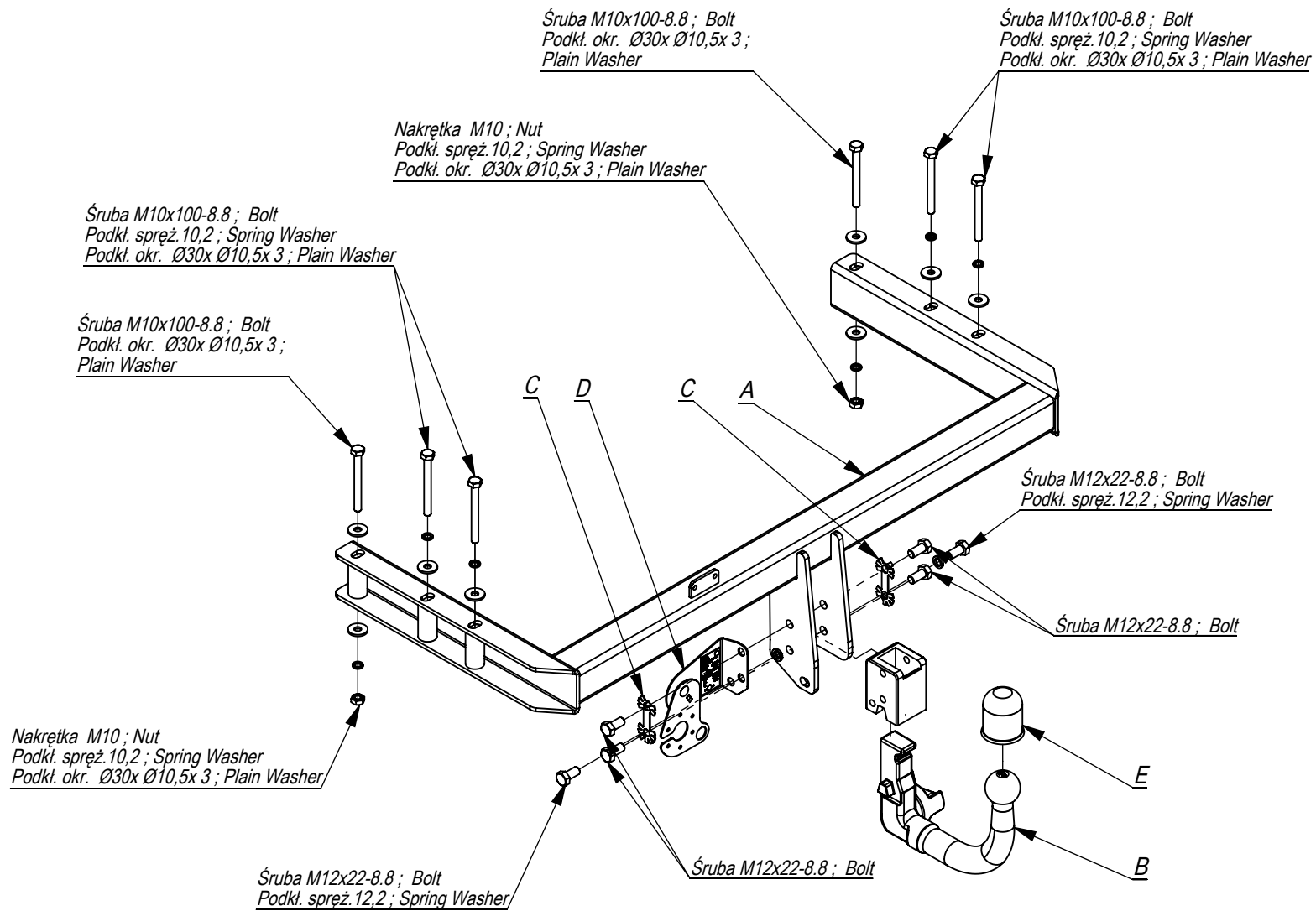
**GB** The clearance specified in appendix VII, diagram 25a/b of Regulation No. 55.01 UN EU must be guaranteed at laden weight of the vehicle.

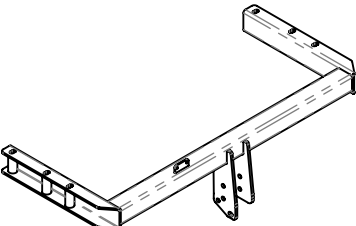
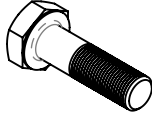
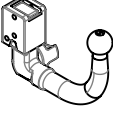
**D** Der Freiraum nach Anhang VII, Abbildung 25a/b der Vorschriften 55.01 EG ist zu gew 25a/bahrleiten bei zulässigem Gesamtgewicht des Fahrzeuges.

Moment skręcający dla śrub i nakrętek (8.8) Torgue settings for nuts and bolts (8.8)	
M8	25Nm
M10	55Nm
M12	85Nm
M14	135Nm
M16	195Nm





	A	x1		M12x22	6
				M10x100	6
	B	x1		M10	2
	C	x2		Ø30xØ10,5x3	8
	D	x1		12,2	2
				10,2	6
	E	x1			

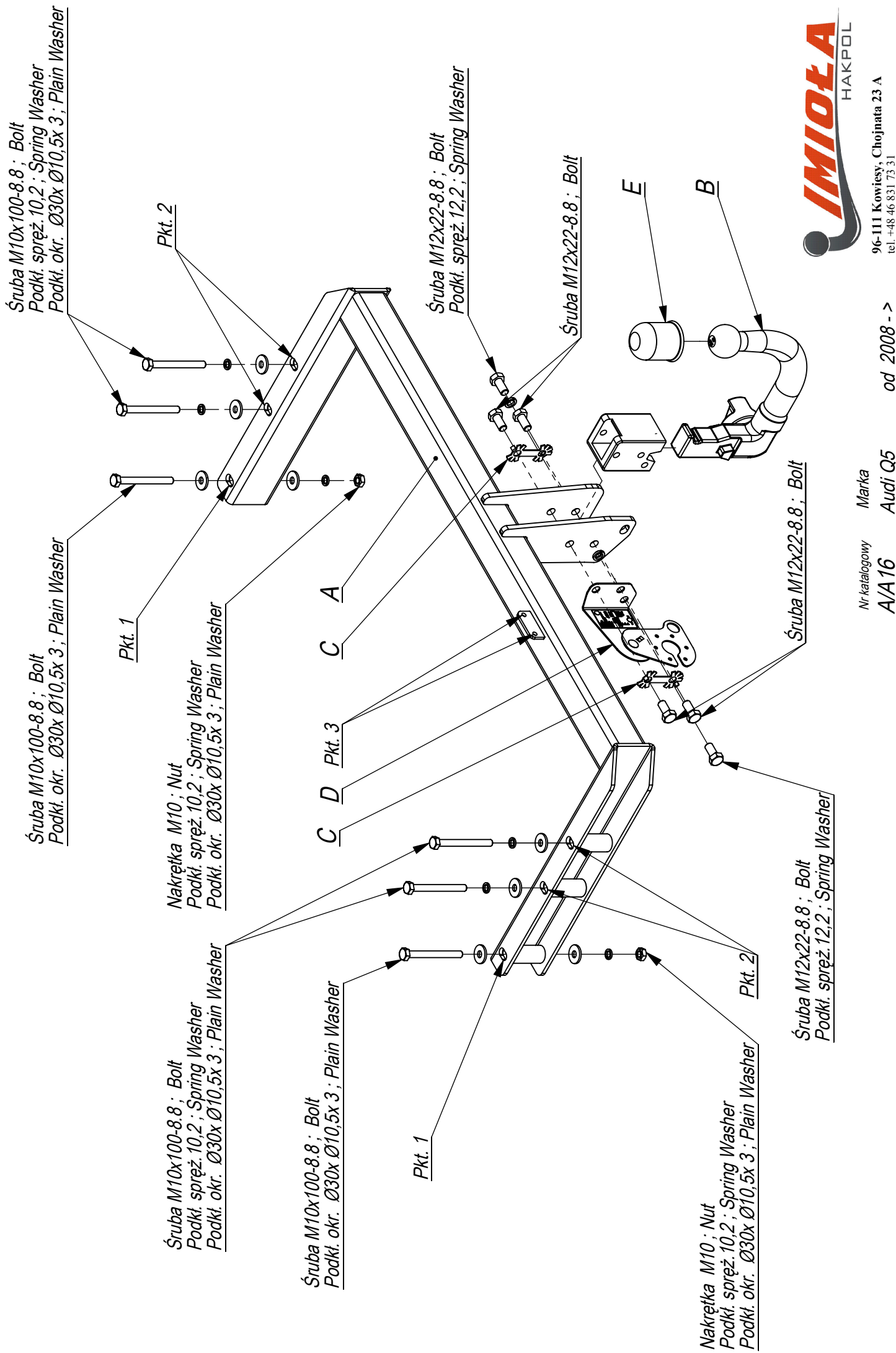

- Odkręcić zderzak.
- Odkręcić belkę zderzeniową (nie będzie już wykorzystana).
- Wsunąć hak do podłużnic i skręcić śrubami M10x100 8.8 (pkt 2) oraz śrubami M10x100 8.8 (pkt 1)
- Wszystkie śruby dokręcić z momentem wg tabeli.
- Przykręcić zderzak.
- Przykręcić kulę i blachę gniazda elektrycznego.
- Podłączyć instalację elektryczną.

- Unscrew the bumper.
- Unscrew the bumper bar (it will not be used any more).
- Insert the tow bar in the metal clamps and screw with bolts M10x100 8.8 (point 2).
- Tighten all the bolts according to the torque setting- see the table.
- Assemble the bumper.
- Fix the ball and electric plate.
- Connect the electric wires.

- Serrer le pare-chocs,
- Dévisser du longerons les xations de pare-chocs (elles ne seront plus utilisées).
- Insérer les bords de crochet D aux longerons, Visser le crochet par les boulons M10x100 8.8 à travers les ouvertures de longerons en utilisant les couvre-joints C
- Visser le crochet d'attelage et socle de prise électrique,
- Raccorder le circuit électrique.
- Serrer tous les boulons avec un couple de serrage selon tableau,

- Die Stoßstange demontieren.
- Den Stoßstange Balken abschrauben (wird nicht mehr benötigt).
- Die Anhängerkupplung in die Längsträger schieben und mit den Schrauben M10x100 8.8 (Punkt 2) und den Schrauben M10x100 8.8 (Punkt 1) verschrauben.
- Alle Schrauben mit dem in der Tabelle angegebenen Drehmoment festschrauben.
- Die Stoßstange anschrauben.
- Die Kugel und die Steckdosenhalterung anschrauben.
- Die Elektroinstallation anschließen.

- Desenroscar el parachoques.
- Desmontar la barra del parachoques (ya no se utilizará)
- Insertar el gancho al chasis y apretar con tornillos M10x100 8.8 (punto 2) y con tornillos M10x100 8.8 (punto 1).
- Apretar todos los tornillos con el par según la tabla anterior.
- Atornillar el parachoques.
- Apretar la bola y la placa de la toma eléctrica.
- Conectar la instalación eléctrica.

